

Model	Rated Voltage V _{DC}	No Load		Rated Load			
		Current	Speed	Load	Current	Speed	
		mA	min ⁻¹	mN·m	mA	min ⁻¹	
KL305	7.2	440	9500	4.0	1000	9000	CW
KL412	12.0	150	4800	10.0	600	3700	CW
KL511	17.0	100	7000	5.0	320	6400	CW
KL551	24.0	65	4700	20.0	520	2800	CW
KL542	24.0	110	7800	9.0	470	6700	CW

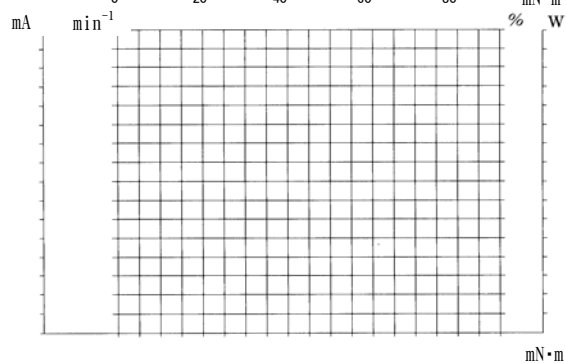
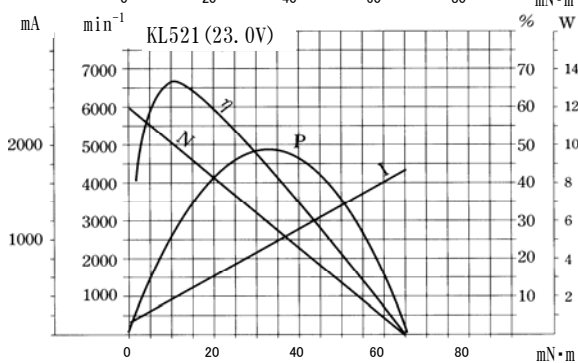
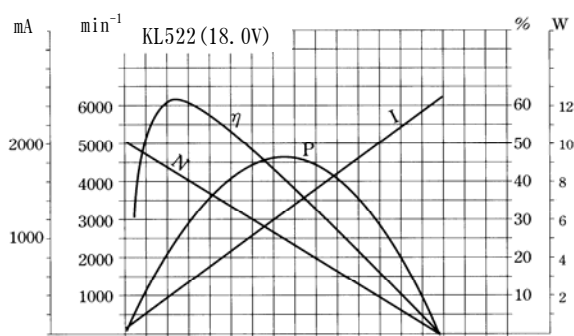
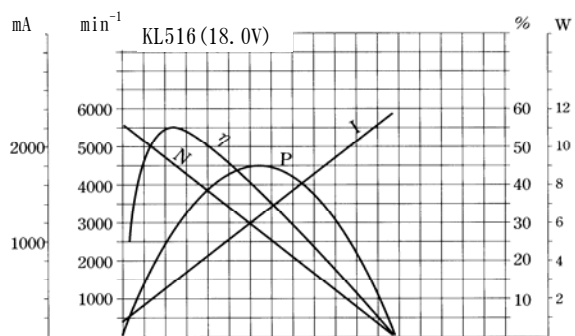
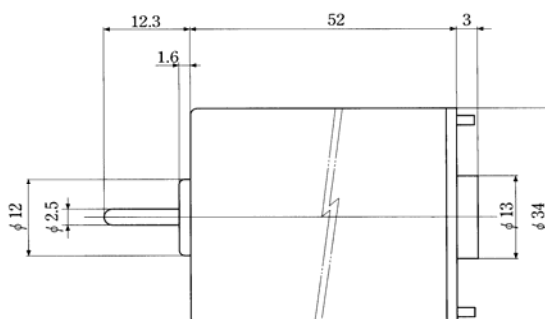
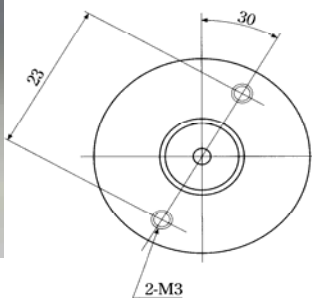

Model	Rated Voltage	No Load		Rated Load			
		Current	Speed	Load	Current	Speed	
	V _{dc}	mA	min ⁻¹	mN·m	mA	min ⁻¹	
KL516	18.0	150	5600	12.0	570	4550	CW
KL522	18.0	110	5100	10.0	410	4400	CCW
KL521	23.0	80	5950	15.0	470	4550	CCW